



FRICAVAL 89 - OEM

Any questions? You may still have questions and/or comments after reading this brochure. Please feel free to contact us on (+34) 961 522 525
For more information about FRICAVAL89 please visit our website
www.fricaval89.com

M500 Pumps



M500

Used extensively in OEM applications with many options.

- Flow rates up to 730 ml/min (11.6 US GPH)
- 3 roller option
- D.C. motor option provides speed/flow rate variations
- Typically used in:
 - Vending
 - Chemical dosing
 - Condensate removal



M500 Free Flow Curve

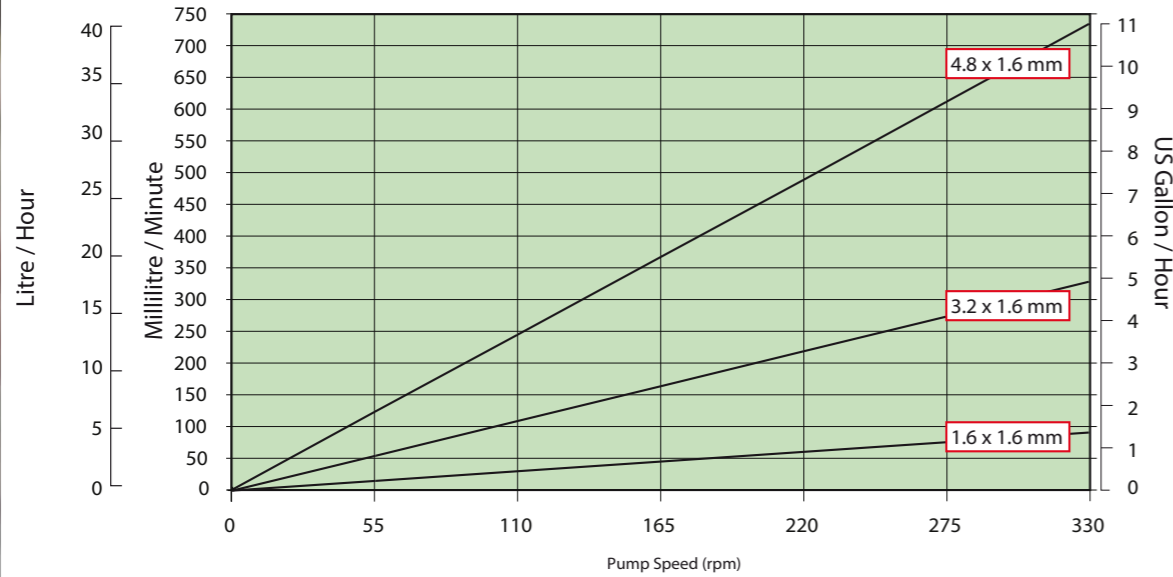

Suction

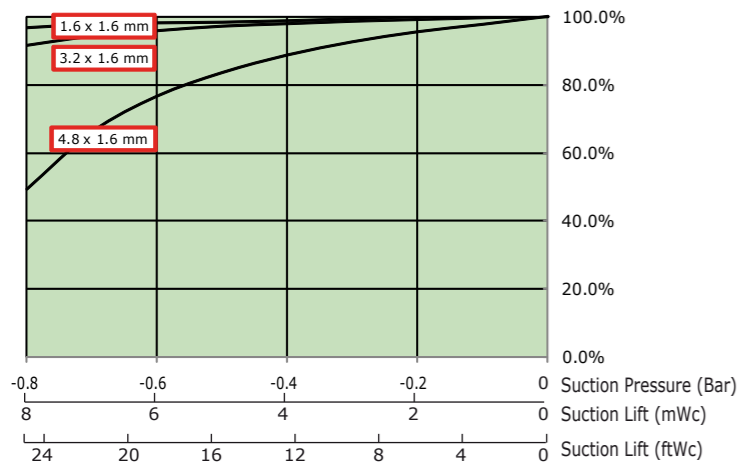

Discharge

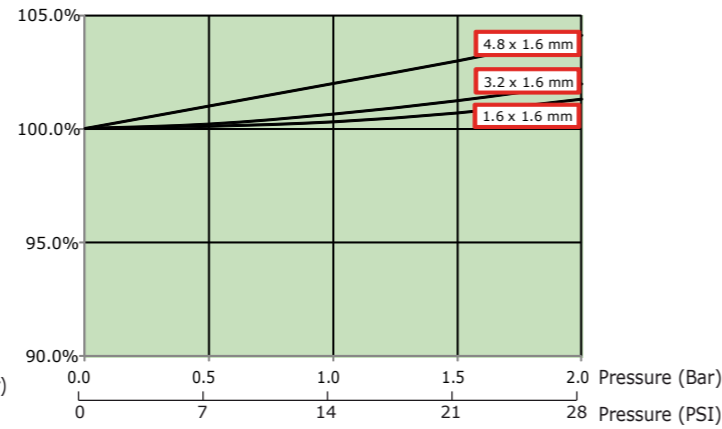

Flow rates with water at 20°C (68°F)

Technical Overview

Function	Detail
Pump head	Polycarbonate - standard Noryl - optional
Motor	Asynchronous shaded pole motor with spur gearbox or D.C.
Rotor	2 Roller Polycarbonate
Options	3 Roller Rotor Different motor stack sizes for varied torque applications: - 3/4", 1", 1 1/2"
Power Supply	12/24V D.C. 20W or 110, 220, 230V 50/60 Hz 100 - 280W
Tube	Verderprene, Silicone, Tygon® and Viton®
Tube Sizes	1.6 x 1.6mm, 3.2 x 1.6mm and 4.8 x 1.6mm
Weight	1.5 kg (3.3 lb)

Tube Size Options

Tube (ID x WT)	30 RPM	51 RPM	125 RPM	240 RPM	325 RPM
1.6 x 1.6 mm (1/16" x 1/16")	8.4 ml/min 0.50 l/hr 0.13 GPH	14.3 0.9 0.2	35.0 2.1 0.6	67.2 4.0 1.1	91 5.5 1.4
3.2 x 1.6 mm 1/8" x 1/16")	30.0 ml/min 1.80 l/hr 0.48 GPH	51.0 3.1 0.8	125 7.5 2.0	240 14.4 3.8	325 19.5 5.2
4.8 x 1.6 mm (3/16" x 1/16")	67.5 ml/min 4.05 l/hr 1.07 GPH	114.8 6.7 1.8	281.2 16.9 4.5	540.0 32.4 8.6	731.3 43.9 11.6

Flow rates for 2 roller option

General Arrangement Drawing and Mounting Positions

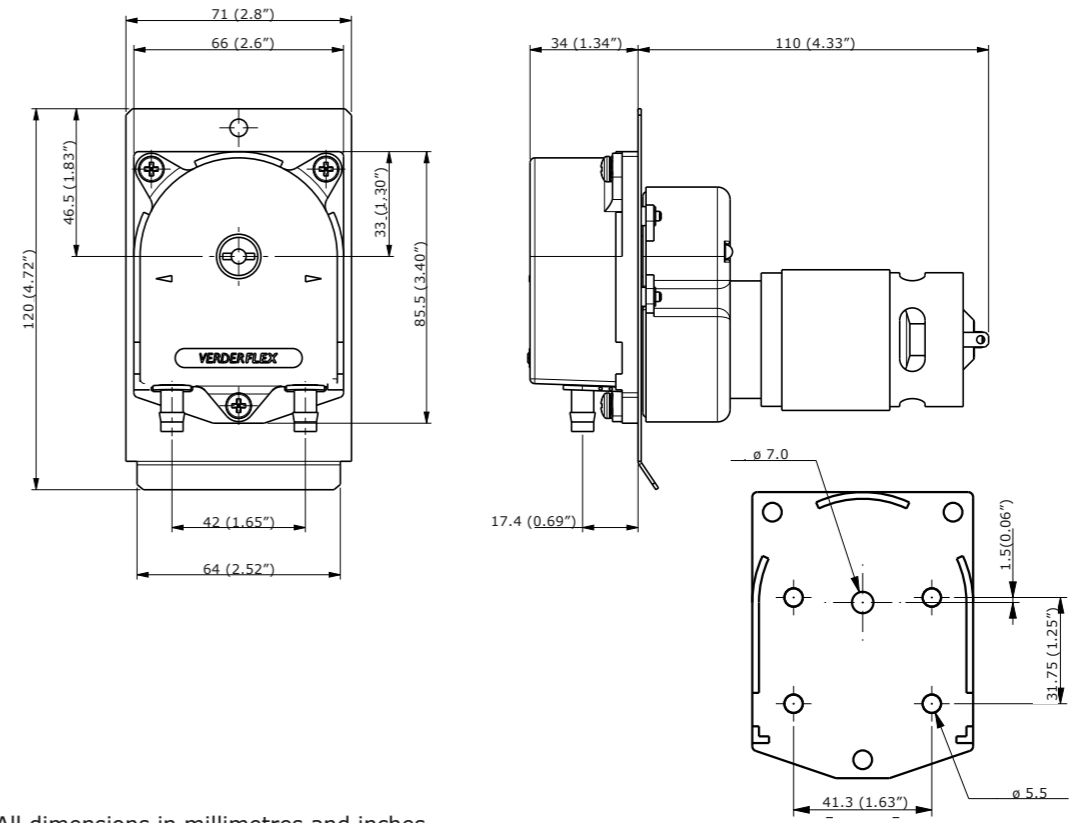

All dimensions in millimetres and inches